

Panasonic

Portable DCC Player

RQ-DP7

Operating Instructions



Notes:

- The "EB" area code, for example, indicates United Kingdom specifications.
- The "EB" indication is shown on the packing case.

Before connecting, operating or adjusting this product, please read these instructions completely.

Dear Customer

Thank you for purchasing this system.
For optimum performance and safety, please read these instructions carefully.

Marking sign is located on bottom of the unit.

WARNING:
TO REDUCE THE RISK OF FIRE OR ELECTRIC SHOCK, DO NOT EXPOSE THIS APPLIANCE TO RAIN OR MOISTURE.

Caution for AC mains lead (For United Kingdom)



("EB" area code model only)

For your safety, please read the following text carefully.

This appliance is supplied with a moulded three pin mains plug for your safety and convenience.

A 5-ampere fuse is fitted in this plug.

Should the fuse need to be replaced please ensure that the replacement fuse has a rating of 5-ampere and that it is approved by ASTA or BSI to BS1362.

Check for the ASTA mark  or the BSI mark  on the body of the fuse.

If the plug contains a removable fuse cover you must ensure that it is refitted when the fuse is replaced.

If you lose the fuse cover the plug must not be used until a replacement cover is obtained.

A replacement fuse cover can be purchased from your local dealer

CAUTION!
IF THE FITTED MOULDED PLUG IS UNSUITABLE FOR THE SOCKET OUTLET IN YOUR HOME THEN THE FUSE SHOULD BE REMOVED AND THE PLUG CUT OFF AND DISPOSED OF SAFELY.
THERE IS A DANGER OF SEVERE ELECTRICAL SHOCK IF THE CUT OFF PLUG IS INSERTED INTO ANY 13-AMPERE SOCKET.

If a new plug is to be fitted please observe the wiring code as shown on the next page

If in any doubt please consult a qualified electrician.

IMPORTANT

The wires in this mains lead are coloured in accordance with the following code:

Blue: Neutral

Brown: Live

As the colours of the wires in the mains lead of this appliance may not correspond with the coloured markings identifying the terminals in your plug, proceed as follows:

The wire which is coloured BLUE must be connected to the terminal in the plug which is marked with the letter N or coloured BLACK.

The wire which is coloured BROWN must be connected to the terminal in the plug which is marked with the letter L or coloured RED.

Under no circumstances should either of these wires be connected to the earth terminal of the three pin plug, marked with the letter E or the Earth Symbol \perp .

Before use

Remove the connector cover as follows.

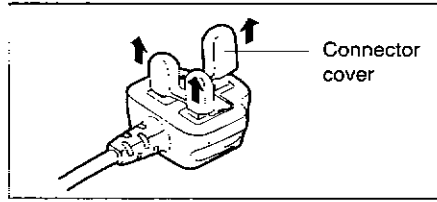

How to replace the fuse

1. Remove the fuse cover with a screwdriver.

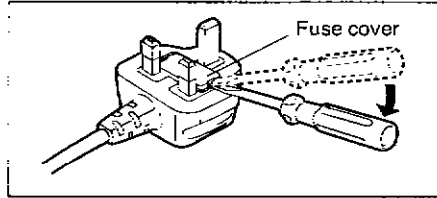

2. Replace the fuse and attach the fuse cover.

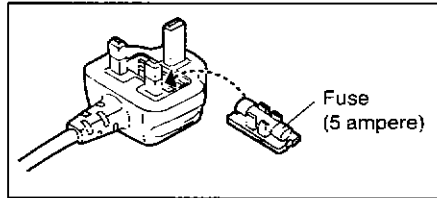

Accessories

Stereo earphones with remote controller (RFEV120P-KS) 1 pc.

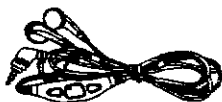

Special rechargeable battery (RP-BP7EY-K)..... 1 pack



Battery charger/AC adaptor

●Main unit 1 pc.

(For U.K.:
RP-BC7EBY-K)
(For Others:
RP-BC7GNY-K)



●Power cable 1 pc.

(For U.K.:
VJA0733)

(For Others:
RJA0035-K)



●DC cable (VJA0669) 1 pc.



Carrying case (RFC0020-K) 1 pc.



Line cable (RJL2P001×10) 1 pc.



DCC prerecorded tape (RFTRD002) 1 pc.



Contents

Preparations

Caution for AC mains lead	2
How to prevent accidental operation	5
Precautions for listening with the headphones	5
Names of the parts	6
Power supply	8

Listening

Listening to tapes	10
Skipping tracks	12
Fast forwarding and rewinding	13
Changing the display	14
Enjoying the deep-bass sound	16
Changing the tape's play side	16
Using the unit together with other components	17
Using the remote controller to operate the unit	18

For your reference

Table of operation messages	20
What is "DCC"?	21
Types and functions of markers	22
Concerning analog tapes	23
Maintenance	23
Operating precautions	24
Troubleshooting guide	25
Technical specifications	26

Notes on procedure descriptions:

[DCC] or **[ACC]** marked for the procedure descriptions denotes the type of tape involved.

[DCC]: DCC (digital compact cassette) tape

[ACC]: Conventional (analog compact cassette) tape

How to prevent accidental operation

(Hold function)

In the hold mode, the unit will not operate, even when one of its function buttons is pressed. This is to prevent incorrect operations and wear on the battery resulting from such operations.

Be sure to release the hold mode before operation.

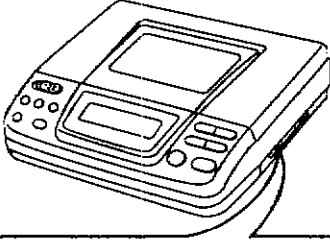

Before operating:

Release the function.



After operating: (To prevent incorrect operation)

Set to the HOLD position.



Release.

Set to HOLD.

◀ HOLD

HOLD ▶

■ When "HOLD ON" appears during operation;

One of the function buttons on the unit was pressed in the hold mode. First, release the mode and try again.

REFERENCES

- The unit can be operated using the remote controller, even in the hold mode.
- When remote control is in hold mode, the unit can be operated using front panel controls.

Precautions for listening with the headphones

- Do not play your headset at a high volume. Hearing experts advise against continuous extended play.
- If you experience a ringing in your ears, reduce volume or discontinue use.
- Do not use while operating a motorized vehicle. It may create a traffic hazard and is illegal in many areas.
- You should use extreme caution or temporarily discontinue use in potentially hazardous situations.
- Even if your headset is an open-air type designed to let you hear outside sounds, don't turn up the volume so high that you can't hear what's around you.

Names of the parts

Main unit

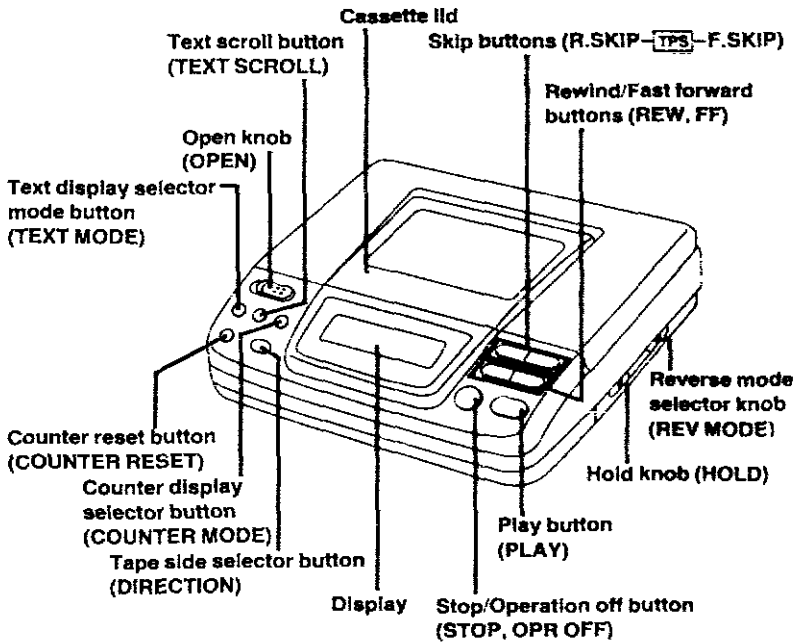

Display

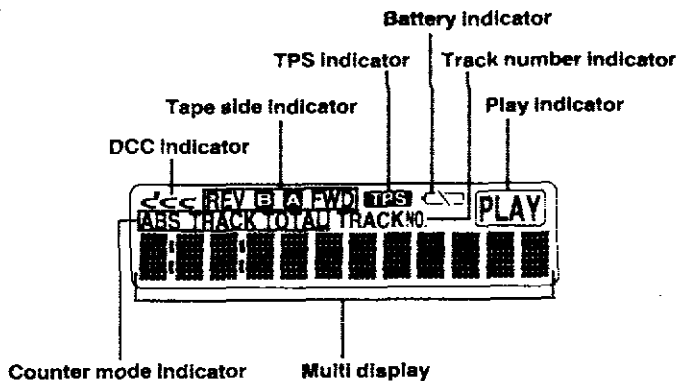

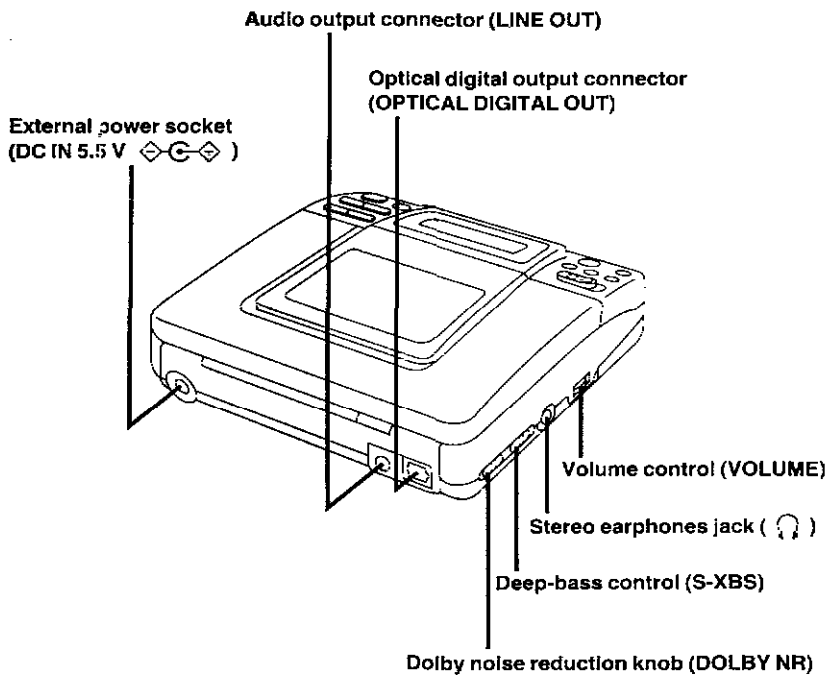

Remote controller

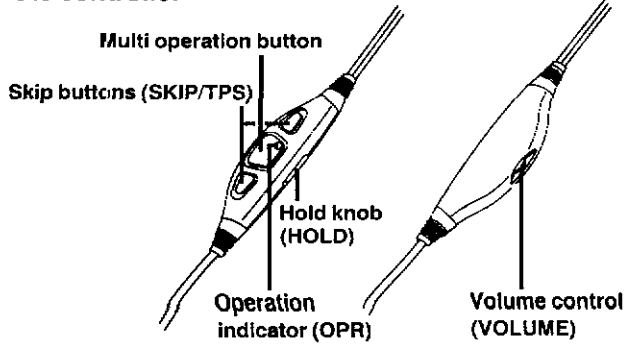

Power supply

This unit is powered by a rechargeable battery or the mains supply using an AC adaptor.

**FOR UNITED KINGDOM ONLY
BE SURE TO READ THE CAUTION
FOR AC MAINS LEAD ON PAGE 2
AND 3 BEFORE USING THE AC
ADAPTOR.**

NOTES:

- The configuration of the AC outlet and AC mains lead differs according to area.
- Some of the AC adaptors on the market have different polarities. Be absolutely sure to use the accessory AC adaptor.
- While the unit is being powered by the supply using the AC adaptor, it is not possible to simultaneously recharge the battery.
- The unit is in the standby condition when the AC adaptor is connected. The primary circuit is always "live" as long as the AC adaptor is connected to an electrical outlet.
- The accessory AC adaptor is for world use. If you use this unit overseas, confirm the configuration of the plug, and purchase the necessary plug adaptor.

To use the AC adaptor

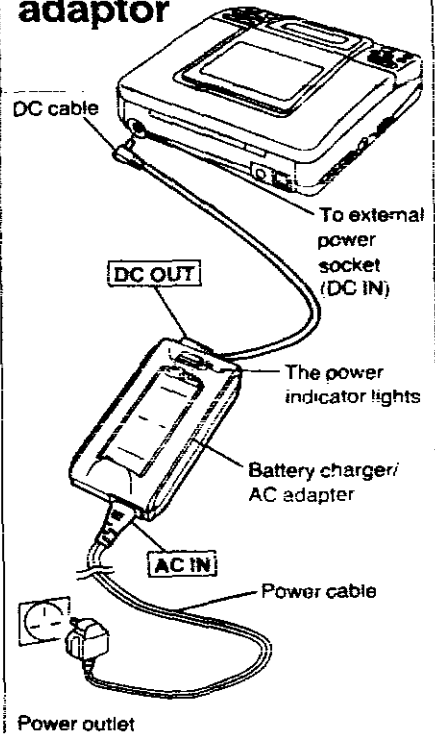

REFERENCE

The light behind the display only comes on when the unit is being powered by the AC adaptor.

Using the rechargeable battery

- 1** Place the rechargeable battery on the battery charger (main unit).

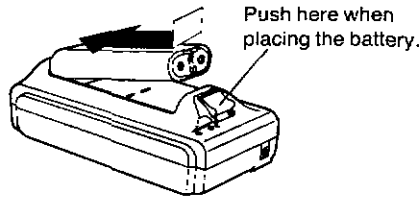

- 2** Charge the battery.

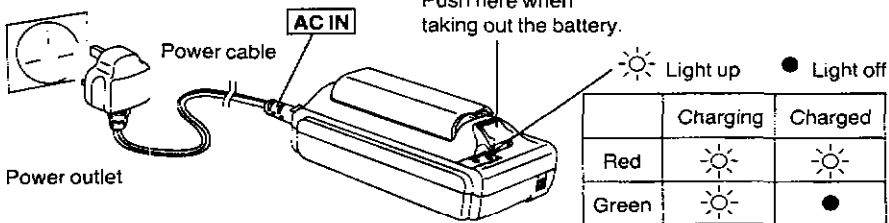

Do not connect the DC cable.
If it is connected, you cannot charge the battery.

- 3** Insert the rechargeable battery into the unit.

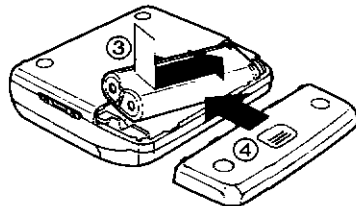
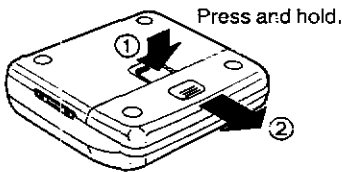

■ **When the battery is nearly flat;**

1. The battery indicator will flash.

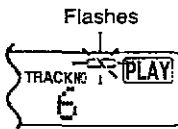

2. Recharge the battery at this point. Otherwise, the battery will become flat, and the power will be automatically cut off.
3. Recharge the battery if the power does not come on when you press PLAY.
(The OPR indicator on the remote control unit may flash at this point.)

Be sure to recharge the battery when you are using it for the first time, or if you have not used it for a long time.
[It provides about 2.5 hours of use with fully recharged (about an hour's recharge) condition.]

NOTE

In case the green indicator turns off soon after you place the rechargeable battery in the battery charger, remove battery from charger and re-insert.

Listening to tapes

Have you released the hold mode? (See page 5.)

DCC

- 1** Connect the stereo earphones (provided with the unit).

R L

- 2** Open the cassette lid and insert the tape.

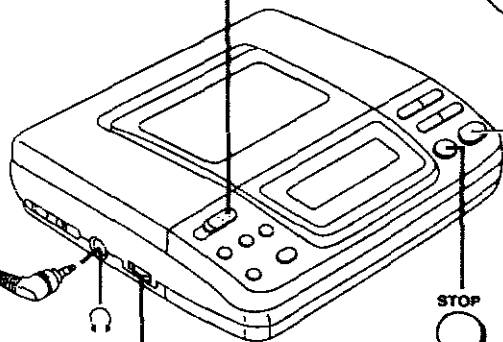
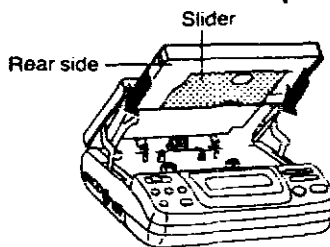

- 6** Set the volume to the desired listening level.



To stop playback at any time



Press STOP/OPR OFF.

To switch off the power



Press STOP/OPR OFF twice.

When taking out the tape

Be sure to set the unit to the stop condition.

To set the reverse mode

REV MODE
C2 1 2



Side A is played back once, followed by side B, and then playback stops automatically.

REV MODE
C2 1 2



Side A is played back, followed by side B, continuously for 8 times, and then playback stops automatically.

3 Close the cassette lid.

Any tape slack is taken up automatically to ensure reliable operation.

(Auto tape setting function)

4 Release the hold mode. (See page 5.)

5 Press PLAY.

The power comes on automatically and playback starts.

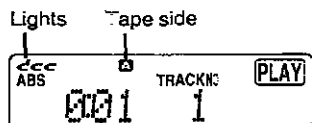

Absolute time display (ABS)

■ What is the "absolute time" (ABS)?

This phrase refers to the time which has elapsed from the start of the tape until the present playback position.

■ The power is turned off automatically under the following circumstances, in order to prevent wear on the battery:

- When the unit has been left in the stop mode for about 4 minutes; and,
- When the tape has been stopped and taken out.

ACC

1. Connect the stereo earphones (provided with the unit).
2. Open the cassette lid and insert the tape.

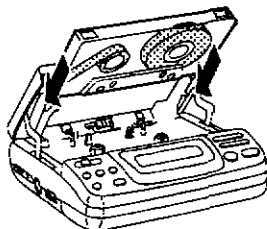

3. Close the cassette lid.
4. Release the hold mode.
5. Press PLAY.

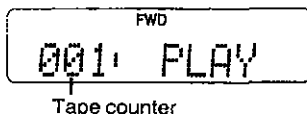

6. Set the volume to the desired listening level.

To select the Dolby NR system



Set the system ON or OFF, depending on the tape to be played.

To set the reverse mode



The forward side is played back once, followed by the reverse side, and then playback stops automatically.



The forward side is played back, followed by the reverse side, continuously for 8 times, and then playback stops automatically.

Skipping tracks

Skipping to the start of a track

DCC

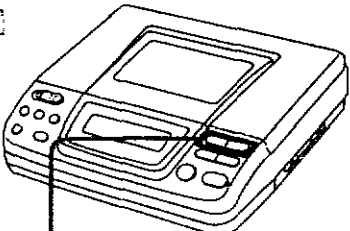

R.SKIP-TPS-F.SKIP

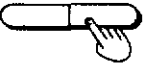

Press F.SKIP to skip to the next track.

Tracks are skipped in the number corresponding to the number of times this button was pressed, and then playback automatically starts.

Flashes



Number of times the button was pressed

R.SKIP-TPS-F.SKIP



Press R.SKIP to skip to the previous track.

When this button is pressed once, the tape is returned to the start of the present track and that track is played.

When the button is further tapped in succession, tracks are skipped in the number corresponding to the number of times this button was pressed.

Flashes



REFERENCES

- Up to 99 tracks in the forward or reverse direction can be skipped.
- If one of the skip buttons, FF or REW buttons is pressed when the power is off, the power will be turned on automatically and the operation performed.

ACC (TPS)

Press F.SKIP below to skip to the next track.

-F.SKIP

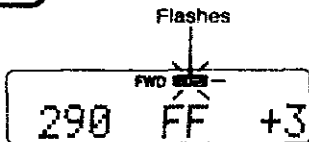

Press R.SKIP below to skip to the previous track.

R.SKIP-

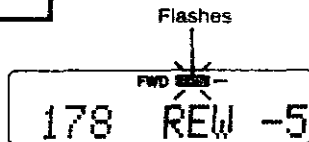

NOTES

The TPS (tape program sensor) may not or will not operate properly in the following circumstances:

- When the unrecorded blank spaces between tracks are 4 seconds or less in length
- When the tape has no unrecorded blank spaces (such as with recordings made from a microphone)
- When tracks have sections with particularly low recording levels or silent passages
- When there are less than 10 seconds from the start of the present track or to the start of the next track
- When the tape was recorded with fade-in and fade-out effects.

REFERENCE

Up to 9 tracks in the forward or reverse direction can be skipped.

Fast forwarding and rewinding

DCC

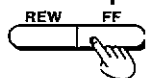
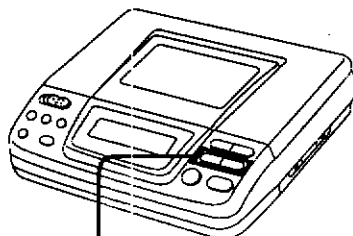

Press FF to fast forward the tape.

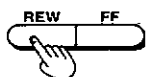
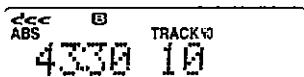

Press REW to rewind the tape.

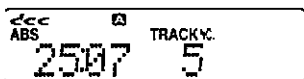

ACC

Press FF to fast forward the tape.

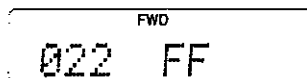

Press REW to rewind the tape.

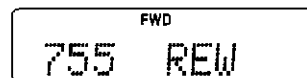

Changing the display

DCC

Changing the text display (characters)

For pre-recorded DCC music tapes only

TEXT MODE Each time **TEXT MODE** is pressed, the display changes as shown below.

Name of album

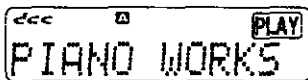

Name of artist

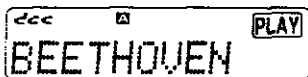

Title of track being played

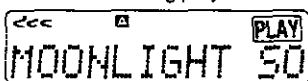

Up to 12 characters can be shown at a time.

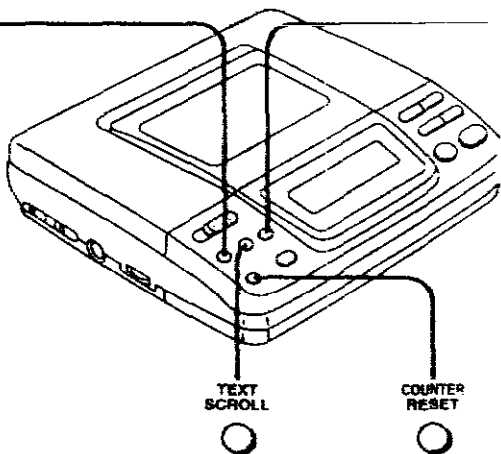

To show 13 or more characters

TEXT SCROLL



Press **TEXT SCROLL**. After the text information has run from right to left, the original display is restored.

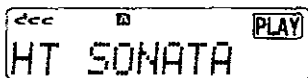

■ When **"READING"** appears on the display:

This means that the unit is still reading the text information on the tape.

■ When **"NO TEXT"** appears on the display:

This indicates that the unit cannot read the text information. The original display is restored.

■ When **"-:--:--"** appears on the display:

This is the tape travel display which appears when the tape's counter information cannot be read.

Setting the counter display (numbers)

COUNTER
MODE



Each time COUNTER MODE is pressed, the display changes as shown below.

Absolute time (ABS)

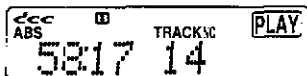

Elapsed time of track (TRACK)

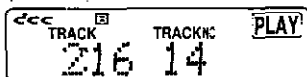

Total play time of tape (TOTAL)

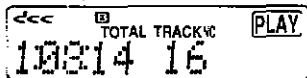

Tape counter

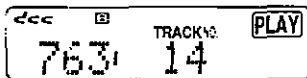

ACC

The display is in the tape counter mode at all times.

To reset the tape counter

COUNTER
RESET



Press COUNTER RE-
SET.

REFERENCE

The tape counter counts backwards when the reverse side is being played back.

To reset the tape counter

COUNTER
RESET



Press COUNTER RE-
SET (while the display is
in the tape counter
mode).

REFERENCE

The tape counter counts backwards when side B is being played back.

Enjoying the deep-bass sound

The bass is effectively boosted at these settings.

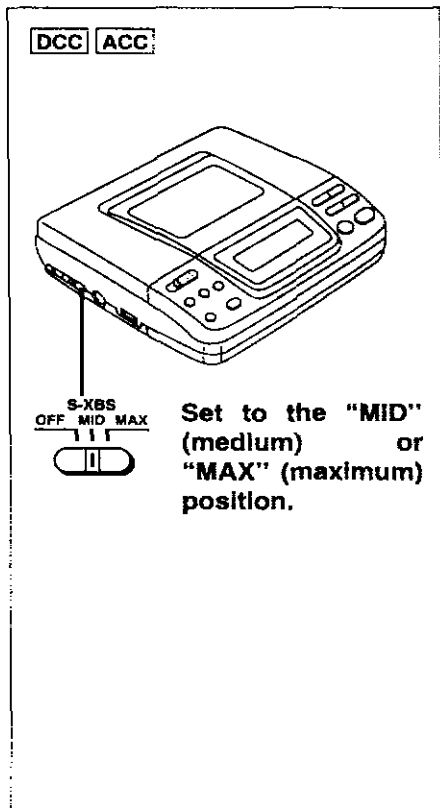

Changing the tape's play side



NOTES

- These settings are effective only when the stereo earphones are used.
- Depending on the music, the sound may be distorted when the switch is set to "MAX". On such occasions, set the switch to "MID" or reduce the volume.

Using the unit together with other components

Switch off the power to the components before connecting the unit.

Analog connections

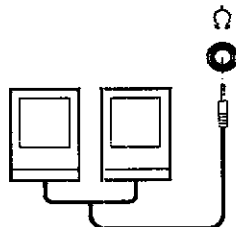
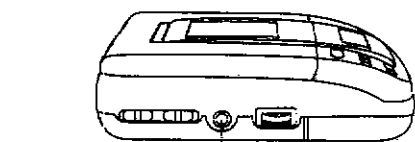
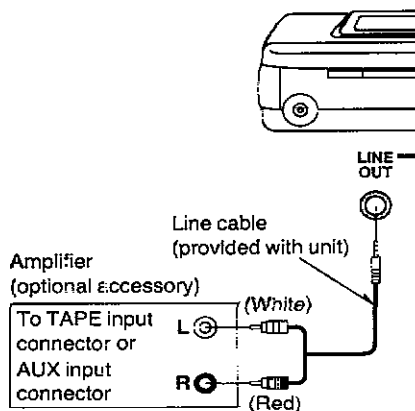

Stereo speakers with built-in amplifiers (optional accessory)

Digital connections

(Only when AC adapter is used)



LINE OUT

OPTICAL DIGITAL OUT

Optical fiber cable (optional accessory)

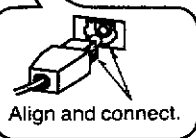
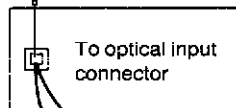

Align and connect.

NOTE

Attach the dust caps to the connectors which are not being used. This will keep them free from dust, which can cause malfunctioning.

■ OPTICAL DIGITAL OUT connector

This is an optical connector, which converts electrical signals into optical signals for transmission. Since it is not susceptible to extraneous electrical noise, it can transmit high-quality digital audio signals.

(Only when playing back the DCC tape)

Using the remote controller to operate the unit

- Any of the operations shown in the figure below can be performed by selecting a button to press and pressing it a certain number of times or for over one second.
- Release the remote controller's hold function before proceeding with operation.
- When you press the button on the remote controller, beep sound can be heard. While in the operation, the verification tone shown in the figure below can be heard.

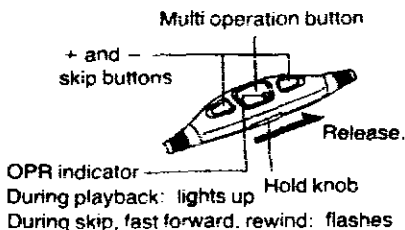

● Press once. ●● Press twice. ●●● Press 3 times. — Press for more than 1 sec. When a button is to be pressed two or more times, press it at intervals that are as equal as possible.			Verification tone
Multi operation button	Stop mode	● → Playback	/
		●● → Fast forwarding → Playback resumes.	Beep, beep
		●●● → Rewinding → Playback resumes.	Beep, beep, beep
		— → Operation OFF	Long beep
	Play-back mode	● → Stop	Beep
		●● → Fast forwarding and playback from reverse side	Beep, beep
		●●● → Rewinding and playback from start of tape	Beep, beep, beep
		— → Changing side of tape to be played	Beep
+ skip	Stop/play mode	Number of times selected → Fast forwarding to desired track and playing back that track	/
- skip	Stop/play mode	Number of times selected → Rewinding to desired track and playing back that track	/

REFERENCES

- When you press the multi-operation button while fast forwarding or rewinding, the playback mode resumes.
- When the volume is to be adjusted on the remote controller, set the volume control on the unit to position 5, 6 or 7.

- Number of tracks which can be skipped using skip buttons

DCC: 99 tracks in forward or reverse direction

ACC: 9 tracks in forward or reverse direction

NOTE

OPR indicator is for verification of the operating condition.

Table of operation messages

	<p>One of the function buttons on the main unit has been pressed in the hold mode. Release the hold mode.</p>
	<p>This is the tape travel display which appears during playback when the DCC tape's counter information cannot be read.</p>
	<p>This means that the unit is still reading the text information on the tape.</p>
	<p>Side A playback has finished. The unit automatically fast forwards the tape to the first track on side B and starts playback.</p>
	<p>Side B playback has finished. The unit automatically fast forwards the tape to the first track on side A and starts playback. (Only when you select "↔" reverse mode)</p>
	<p>Side B playback has finished. The unit automatically fast forwards the tape to the tape end on side B and stops playback. (Only when you select "↔" reverse mode)</p>
	<p>You are not using a pre-recorded DCC music tape. The unit cannot read the text information, so the original counter display will be restored.</p>

What is "DCC"?

Construction of DCC tapes

Unlike conventional analog tapes, DCC tapes have a slider to protect the tape and hubs. This is to prevent dust and dirt which cause dropouts (momentary loss of signal)—the arch enemy of digital recordings—from entering inside the tapes. (Shown below is an example of a DCC blank tape.)

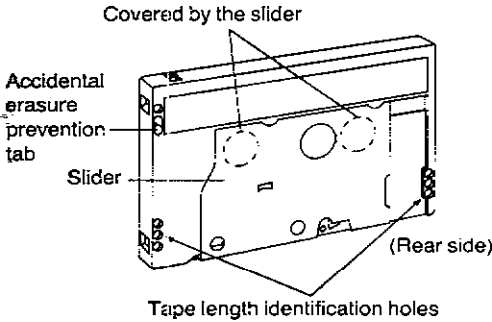

Types of DCC tapes which can be played back

- Pre-recorded DCC music tapes
- DCC tapes recorded on other components

Handling precautions

To prevent imperfect operation and failures, do NOT:

- Turn over like analog tapes. DCC tapes must be inserted only in one way.
- Open the slider, touch the tape or pull the tape out.
- Open up or block up the tape length identification holes.
- Drop the tape, bang it into anything or subject it to severe vibration.

Be sure to use DCC tapes with a unit having the  mark.

To prevent failures, do not insert DCC tapes into the analog cassette deck and so on.

Storage precautions

Store DCC tapes inside the cases that come with the tapes.

Do NOT store them where:

- The temperature is high (above 40°C) or the humidity level is high (over 80%).
- There is a source of magnetism (near speakers or on top of a TV set, etc.).
- They will be exposed to direct sunlight.

Types and functions of markers

■ What are "markers"?

In addition to the audio signals, signals serving as markers are also recorded onto a DCC tape. The unit detects the markers shown in the table below and automatically controls the tape operations and volume. You cannot record markers onto a DCC tape using this unit.

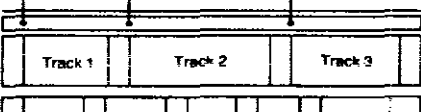
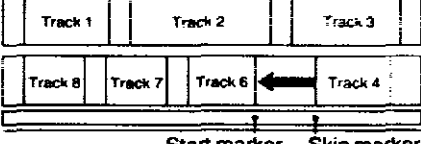
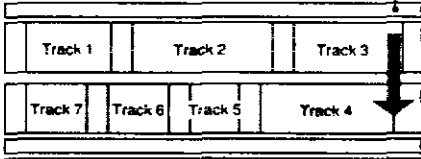
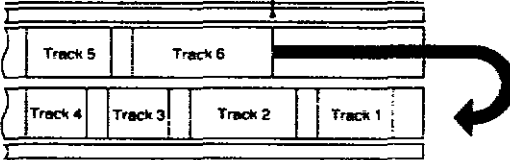
Marker type and function	Description
<p>● Start marker: For finding the start of a track</p>	<p style="text-align: center;">Start marker Start marker Start marker</p>  <p>Side A</p>
<p>● Skip marker: For skipping to the start of the next track</p>	 <p>Side A</p> <p>Side B</p> <p style="text-align: center;">Start marker Skip marker</p>
<p>● Reverse marker: For skipping the blank part at the end of the tape and quickly changing over to the other side</p>	<p style="text-align: center;">Reverse marker</p>  <p>Side A</p> <p>Side B</p>
<p>● Next marker: For fast forwarding to the end of the tape and changing over to the other side</p>	<p style="text-align: center;">Next marker</p>  <p>Side A</p> <p>Side B</p>

Concerning analog tapes (ACC)

Types of tapes which can be used

Normal, chromium and metal tapes can be used.

Tapes exceeding 90 minutes in length

These tapes may come in handy for long-duration play but it should be borne in mind that since they are thin and easily stretched, they may become wrapped around the rotating parts with repeated piecemeal playback, stop, fast forwarding and rewinding.

Take up any tape slack.

Tape slack can mark the tape and/or cause it to snap.



When storing tapes

Do NOT store them where:

- They will be exposed to direct sunlight.
- The temperature is high (above 40°C) or the humidity level is high (over 80%).
- There is a source of magnetism (near speakers or on top of a TV set, etc.).

Maintenance

Main unit

Wipe the main unit with a soft cloth. With ingrained dirt, wipe with a cloth which has been dipped in water or a soap solution and wrung out, and then wipe with a dry cloth.

Do not use alcohol or paint thinners.

If you intend to use a chemically treated cleaning cloth, refer to the directions for its use first.

Head section

Use a cleaning kit for the best results in sound quality.

You may also use a cleaning tape designed for analog cassette decks.

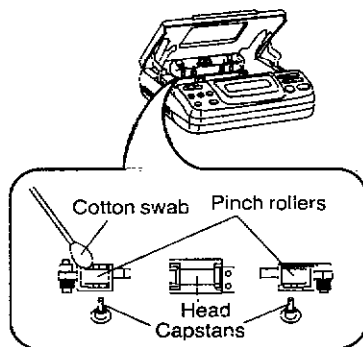

Never touch the head directly. For cleaning, use a cotton swab.

Never use any type of head demagnetizer.

Using the head demagnetizer badly damages the head.

Stereo earphones plug

If the sound is cut off or if a crackling sound is heard when the plug is rotated, wipe the plug clean.

Operating precautions

Recharging the battery

- While recharging, the AC adaptor and the rechargeable battery may get warm. This is normal.
- Do not use the rechargeable battery accompanying this unit with any other product.
- Only use the battery charger enclosed with this unit.
- When the battery is recharged for the first time or used again after a prolonged break, it may not operate for as long as usual even if it is recharged. However, after repeated charging and discharging, it will be restored to its usual operating time.
- Recharging may be difficult in low temperatures. Therefore, try to recharge the battery where the room temperature is 10°C–35°C.
- In certain conditions, the battery life may be shorter than usual. For example, in very low temperatures.
- If the battery charge lasts only for a very short time even after charging or if the charging indicator fails to light after recharging has started, it means that the battery has reached the end of its service life. Do not use it any longer.
Replace the battery with new one.
- If the rechargeable battery is put inside a pocket or bag to be carried around, make sure that no necklaces or other metal objects are present. Contact with metal may cause the battery to short-circuit and generate heat.
- Do not expose the rechargeable battery to a naked flame.

Keep the unit at a distance from tuners or TV sets.

Otherwise, noise interference with audio or video reception may result.

If distancing the unit has no effect, turn off the unit's power. Disconnect the power cable if one was being used to power the unit.

Dolby noise reduction

This is a system for reducing the tape hiss which is inherent to ACC tapes. It boosts the level of the high frequency parts during recording and restores them to their original level during playback. This unit is equipped with the B type of Dolby noise reduction.

The B type system cuts tape hiss to approximately one-third. It is the type generally used with pre-recorded analog music tapes and equipment on which "DOLBY NR" is marked (without the actual type of noise reduction specified).

Noise can only be reduced if the tape was recorded using the Dolby NR system. It cannot be reduced by using the system during playback only.

Dolby noise reduction manufactured under license from Dolby Laboratories Licensing Corporation.
"DOLBY" and the double-D symbol  are trademarks of Dolby Laboratories Licensing Corporation.

Stereo earphones

- Keep the stereo earphones volume at a level which will not overtax your ears or be a nuisance to those around you.
- In the interest of traffic safety, never use the stereo earphones while riding a bicycle or motorcycle or while driving a car or other vehicle.
If the volume is set high, it is harder to hear the sounds outside and around you. For this reason, using the stereo earphones may be dangerous even while walking. Pay sufficient attention to the surrounding traffic conditions at level crossings or pedestrian crossings.
- When winding the stereo earphone line around the unit, ensure that the line is not too tight.

Troubleshooting guide

Before requesting service for this unit, check the chart below for a possible cause of the problem you are experiencing. Some simple checks or a minor adjustment on your part may eliminate the problem and restore proper operation.

If you are in doubt about some of the check points, or if the remedies indicated in the chart do not solve the problem, refer to the directory of Authorized Service Centers (enclosed with this unit) to locate a convenient service center, or consult your dealer for instructions.

Symptom	Check	Remedial action	Page
Both DCC and ACC			
No recharging.	Is the DC cable still connected?	Disconnect the DC cable from the AC adaptor.	9
No operation.	Is the unit still in the hold mode?	Release the hold mode.	5
	Has the AC adaptor been connected properly?	Connect it properly.	8
	Is the rechargeable battery flat?	Recharge it.	9
Broken/intermittent playback sound.	Is the head section dirty?	Clean the head section.	23
	Is the tape old?	Use a new tape.	
The unit cannot be operated when you press PLAY, and the OPR indicator on the remote control unit flashes.	Is the rechargeable battery flat?	Recharge it.	9
DCC			
Track number or elapsed play time is not displayed properly.	Has the tape been loaded in the middle of one of the tracks?	Rewind to the start of the track and play it back.	12
ACC			
Poor sound quality during playback.	Has the Dolby NR knob been set incorrectly?	Set the knob to the position corresponding to the tape.	11

Technical specifications

Digital format

Tape recording system	Digital compact cassette
Sampling frequencies	
For playback	48 kHz, 44.1 kHz, 32 kHz (automatically)
No. of quantizing bits	16-bit, linear
Data processing system	PASC
No. of channels	2-channel, stereo

DCC playback

Frequency response	
fs: 44.1 kHz	20 Hz–20 kHz +0.5 dB, –1.5 dB
fs: 48 kHz	20 Hz–22 kHz +0.5 dB –1.5 dB
fs: 32 kHz	20 Hz–14.5 kHz +0.5 dB, –1.5 dB
Dynamic range	90 dB or more (A-weighted)
S/N	90 dB or more (A-weighted)
Wow and flutter	Below measurable limit

ACC playback

Deck system	Stereo cassette player
Track system	4-track, 2-channel, stereo
Frequency response (Dolby NR off)	
Normal	20 Hz–18 kHz (DIN)
CrO ₂	20 Hz–18 kHz (DIN)
Metal	20 Hz–18 kHz (DIN)

Terminals

Analog output (fixed)	
Output level	1.0 V (50 k Ω load)
Headphones output	
Output level (max.)	15 mW + 15 mW (16 Ω load)
Digital output	Optical (only when AC adaptor is used)

Mechanism

Head	18 channel thin-film head \times 1
Motor	Brushless motor \times 1
Tape speed	4.76 cm/sec (1 $\frac{7}{8}$ ips)

General

Dimensions (W\timesH\timesD)	120.0 \times 35.5 \times 118.0 mm
Weight (with battery)	490 g
Power supply	
DC	5.5 V
AC (Using AC adaptor)	100–240 V, 50/60 Hz
Power consumption (Using AC adaptor)	4.8 W

Note:

Specifications are subject to change without notice.

Weight and dimensions are approximate

This apparatus was produced to BS 800